

Battery electric vane self-priming pump 12 or 24V direct electricity, constituted by cast iron body, sintered steel impeller and acetyl resin vane. Built-in by-pass valve and stainless steel filter.



Battery electric pump 45 l for diesel transfer equipped with:

Power cable 2 m length sec. 2,5 mmq with pincers and fuse

Power cable 4 m length sec. 4 mmq with pincers and fuse

Self-priming rotary electric pump

Cast iron body

By-pass valve

DC engine

Stainless steel filter 100 micron

Motor protection rating IP55

Ref.	Flow rate	Voltage	Power	Electricity	Cable length	Inlet-Outlet	Duty cycle	Max suction height	Weight	Packaging
	l/min	DC Volt	W	A	m	BSPG	min	m	kg	mm

091-5080-045	45	12	264	18	2	F 1"-F 1"	40	3	5,10	250X195X210
091-5081-045	45	12	264	18	4	F 1"-F 1"	40	3	5,10	250X195X210
091-5082-045	45	24	312	10	2	F 1"-F 1"	40	3	5,10	250X195X210
091-5083-045	45	24	312	10	4	F 1"-F 1"	40	3	5,10	250X195X210

Dimensions:

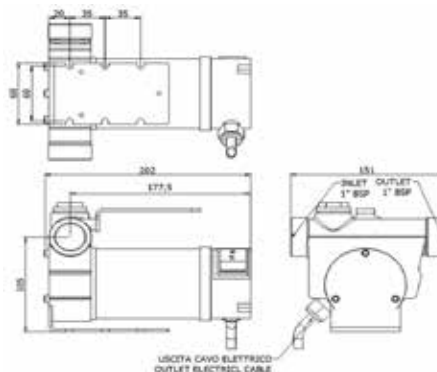

BATTERY ELECTRIC PUMPS FOR DIESEL FUEL TRANSFER



Battery electric vane self-priming pump 12 or 24V direct electricity, constituted by cast iron body, sintered steel impeller and acetyl resin vane. Built-in by-pass valve and stainless steel filter.



Battery electric pump 60 l for diesel transfer equipped with:

Power cable 4 m length sec. 4 mmq with pincers and fuse

Self-priming rotary electric pump

Cast iron body

By-pass valve

DC Engine

Stainless steel filter 100 micron

Motor protection rating IP55

Ref.	Flow rate	Voltage	Power	Electricity	Cable lenght	Inlet-Outlet	Duty cycle	Max suction height	Weight	Packaging
	l/min	DC Volt	W	A	m	BSPG	min	m	kg	mm

091-5081-060	60	12	336	19	4	F 1"-F 1"	40	3	6,70	250X195X210
091-5083-060	60	24	432	11	4	F 1"-F 1"	40	3	6,70	250X195X210

Dimensions:

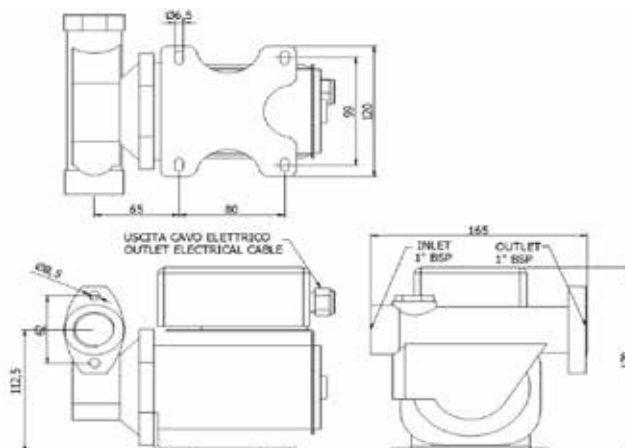

Battery electric vane self-priming pump 12 or 24V direct electricity, constituted by cast iron body, sintered steel impeller and acetyl resin vane. Built-in by-pass valve and stainless steel filter.



Battery electric pump 85 l for diesel transfer equipped with:

- Power cable 4 m length sec. 6 mmq with pincers and fuse
- Self-priming rotary electric pump
- Cast iron body
- By-pass valve
- DC Engine
- Stainless steel filter 100 micron
- Motor protection rating IP55

Ref.	Flow rate	Voltage	Power	Electricity	Cable Length	Inlet-Outlet	Duty cycle	Max suction height	Weight	Packaging
	l/min	DC Volt	W	A	m	BSPG	min	m	kg	mm

091-5081-085	85	12	432	40	4	F 1"-F 1"	S2 30	2	9,50	300X215X230
091-5083-085	85	24	432	32	4	F 1"-F 1"	S2 30	2	9,50	300X215X230

Dimensions:

