

AIR-OPERATED GREASE PUMPS Mod. 670

COMPRESSION RATIO = 70:1

DELIVERY = 1100 g/min



Art. 010-1018-000

Air-operated grease pump R=70:1 Mod. 670

For standard drums **12-16 kg**

(shank length 410 mm)

Polyurethane seals

Art. 010-1020-000

Air-operated grease pump R=70:1 Mod. 670

For standard drums **18-30 kg**

(shank length 480 mm)

Polyurethane seals

Art. 010-1025-000

Air-operated grease pump R=70:1 Mod. 670

For standard drums **50-60 kg**

(shank length 750 mm)

Polyurethane seals

Art. 010-1030-000

Air-operated grease pump R=70:1 Mod. 670

For standard drums **180-220 kg**

(shank length 950 mm)

Polyurethane seals

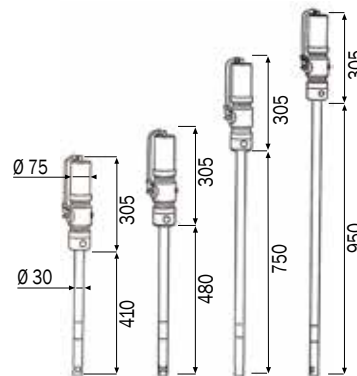

Art. No.	Weight (Kg)	Volume (m³)	Quantity (No.)
010-1018-000	5,400	0,010	1
010-1020-000	5,600	0,010	1
010-1025-000	6,800	0,013	1
010-1030-000	7,000	0,016	1

Technical data		010-1018-000	010-1020-000	010-1025-000	010-1030-000
Compression ratio		70:1	70:1	70:1	70:1
Max pressure supply	bar	8	8	8	8
Medium air consumption	l/min	150	150	150	150
Air inlet connection	BSP	F 1/4" G	F 1/4" G	F 1/4" G	F 1/4" G
Grease outlet connection	BSP	M 1/4" G	M 1/4" G	M 1/4" G	M 1/4" G
Grease delivery capacity 8 bar g/min		1100	1100	1100	1100
Noise	dB	76	76	76	76
Shank diameter	mm	30	30	30	30
Shank length	mm	410	480	750	950
For drums with capacity of	kg	12-16	18-30	50-60	180-220

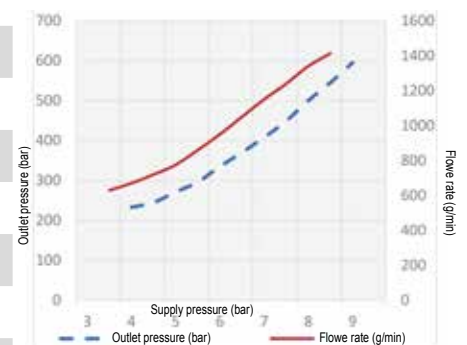

(GREASE NLGI 1 20° C)

These pumps are suitable for the supply at high pressure of greases with viscosity up to NLGI 2 at short and long distances. The operating pressure of the grease pumps hereby may vary between a minimum of 2.5 bar and a maximum of 8 bar. In order to optimize the efficiency and the life of our air-operated pumps, we recommend to use filtered and lubricated air.